

# DECKS

THE PURPOSE OF THIS BROCHURE IS TO ANSWER QUESTIONS YOU MAY HAVE AND HELP YOU ACHIEVE A SAFE AND PROPER BUILDING PROJECT.

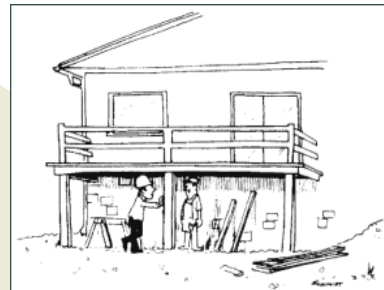

Building Division  
18 N. Jackson Street - 3rd floor  
PO Box 5005  
Janesville, WI 53547-5005



**JANESVILLE**

Building Division | 608-755-3060

Phone: 608-755-3060  
E-mail: [ruschl@janesvillewi.gov](mailto:ruschl@janesvillewi.gov)  
[millerv@janesvillewi.gov](mailto:millerv@janesvillewi.gov)

## Permit Procedure

In order to obtain a building permit for your deck, the following information must be provided:

1. A completed building permit application signed by either the property owner who resides in the house or a Certified Dwelling Contractor. The permit fee is \$.16 per square foot with a minimum fee of \$110.00.
2. A plot plan indicating lot dimensions, location of the house, the proposed deck and any other outbuildings. This plot plan must also indicate the distances from the deck to all property lines and any other detached buildings.
3. It is the responsibility of the applicant to verify the existence of easements and properly label them on the plot plan. Structures are prohibited from being constructed within easements. The City of Janesville is not responsible to determine easement locations OR for errors/mis-representations made by the applicant.”
4. The floor plan drawn to scale. Including:
  - Deck size
  - Size and spacing of floor joists
  - Size, type and spacing of posts
  - Size of footings
  - Size and type of beams

Most simple deck permits can be approved in a few minutes while you wait. Complex design may require additional review time.

**Don't forget to call:**  
**Diggers Hotline**  
**1-800-242-8511 or log on to**  
**[www.diggershotline.com](http://www.diggershotline.com)**

## Inspections

Inspections are required at various stages of construction. The following types of inspections are required:

1. Footing Inspection– When the deck holes are dug and before any concrete is poured.
2. Rough Framing– When the framing is completed and prior to installing any floor boards.
3. Final Inspection- After all work is completed including stairs, handrails and guardrails.

## Please Remember

Building Division staff is available to answer your questions and help you achieve a safe and proper building project. We urge you to obtain a permit and have your work inspected for compliance. You will not only be complying with the law, you will be protecting your family.

If you have any questions, please call Building Division at (608) 755-3060 from 7:30 am to 4:30pm, Monday through Friday.

## Definitions

**Cantilever:** The part of a deck that overhangs a supporting beam or wall.

**Frost Footing:** A poured concrete pad placed in an excavation hole or trench, the bottom of which is at least 48" below finished grade.

**Guardrail:** The railing surrounding a deck.

**Handrail:** The railing going down the steps.

**Riser:** The height of the steps measured from the top of one step to the next.

**Run:** The depth of each step measured from riser to riser.

**Setback:** The minimum distance a building or structure must be from a lot line or another structure.

**Site Plan:** A drawing of the property showing the location of the home, other structures, easements and electric lines.

**Joist Size:** 2x6, 2x8, 2x10, etc.

**Spacing:** Distance between floor joists.

## Setbacks

**Front Setback:** Decks on the front of the house must be a minimum of 17 feet from the front property line. (Decks with roofs must be set back a minimum of 25'.)

**Rear Setback:** Decks must be 17 feet from the rear property line.

**Side Setback:** Decks must be 4 feet from all side property lines.

**Corner lots** have different requirements-please call Building Division for further assistance.

## Piers, Pads and Foundations

General footings, pads or piers shall be of adequate bearing area to safely distribute all live and dead loads to the supporting soil without exceeding the bearing capacity of the soil.

All decks located within 5 feet of the house are considered attached (whether or not they are physically secured to the building) and require a frost footing.

**Deck Holes:** The minimum depth of all deck holes shall be 48" below grade and a minimum of 8" in diameter. The base of the hole shall be filled with at least 8" of concrete. Some point loads may exceed the minimum requirement and require larger diameter footings. Sonotubes are permitted. The number of holes required is based on the design of your deck. Your application should include where you propose deck holes. Staff will verify that your design is adequate.



## Framing

**Materials:** All wood framing used in deck construction shall be pressure-treated against decay or a species of wood that is naturally decay resistant.

**Fasteners:** It is very important that when you purchase hardware including lag screws, washers, joist hangers, screws and other fasteners in contact with pressure treated wood that they are stainless steel, silicon bronze, copper, G185 galvanized steel or hot dipped after fabrication. Examples of these types of fasteners are Zmax185, HDG, or sst300 stainless steel.

**Joist and Beam Size and Span:** The size and span of beams is specific to each deck design. Your lumberyard should be able to assist you in the design of your deck. Building Division will verify that your deck is designed adequately before a permit is issued.

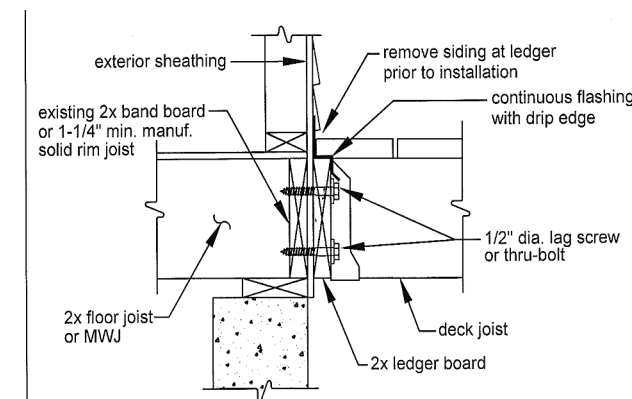
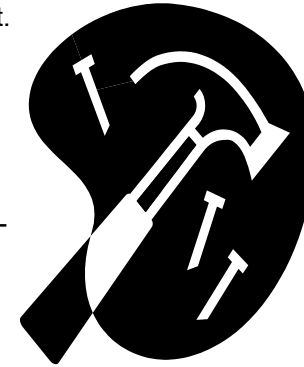

Attachment of Ledger Board to Band Board

## Stairs, Handrails & Guardrails

**Stairs:** Risers cannot exceed 8" measured tread to tread and the run must be at least 9" measured nosing to nosing. All risers and runs must be the same from the top of the stairs to the bottom. Stairs must measure 36" in width (handrails may project a maximum of 4.5" at each side of the stairway).

**Guardrails:** Guardrails are required if the deck will be more than 24" above grade. Guardrails must be at least 36" high and spindles spaced so that a 4-3/8" sphere may not pass through.

**Handrails:** Handrails are required on stairs with more than three risers. The top of the handrail must be 30 to 38" measured vertically in line with the riser. Handrails shall be constructed such that a 4-3/8" sphere may not pass through. Handrails shall have a graspable surface (see additional handrail handout). Handrails shall be symmetrical about the vertical center line to allow an equal gripping surface. Round handrails shall have a maximum diameter of 2". Rectangular or other configured handrails shall have a maximum horizontal cross section of 2-7/8" with a minimum clearance between a handrail and the adjacent wall or guardrail surface shall be a minimum of 1-1/2".

**Basement Egress Window** when installed below a deck, shall have a minimum travel path from the window of 36" wide by 36" high for a distance no greater than 15 feet.